

HYPERPRO

STEERING DAMPER MOUNTING KIT

for

BMW R1200 GS (Adventure) Model 2004>

MK-BM12-B002 PART LIST

SD stroke 75	1	Washer M8 ϕ 16	2
Damper Clamp (DB018235)	1	-	-
Fork Clamp ϕ 55 (FC0550)	1	-	-
Frame Bracket 1 (FRMK26-1)	1	-	-
Frame Bracket 2 (FRMK26-2)	1	-	-
O-Ring	2	-	-
M6x30	2	-	-
M8x25 Button head	2	-	-

ALL IDEAS, DESIGNS, ARRANGEMENTS AND PLANS INDICATED OR REPRESENTED BY THIS DRAWING ARE OWNED BY HYPERPRO AND WERE CREATED, EVOLVED AND DEVELOPED FOR USE ON AND IN CONNECTION WITH THE SPECIFIC PROJECT. NONE SUCH IDEAS, DESIGNS, ARRANGEMENTS OR PLANS SHALL BE USED BY OR DISCLOSED TO ANY PERSON, FIRM OR CORPORATION FOR ANY PURPOSE WHATSOEVER WITHOUT THE WRITTEN PERMISSION OF HYPERPRO.

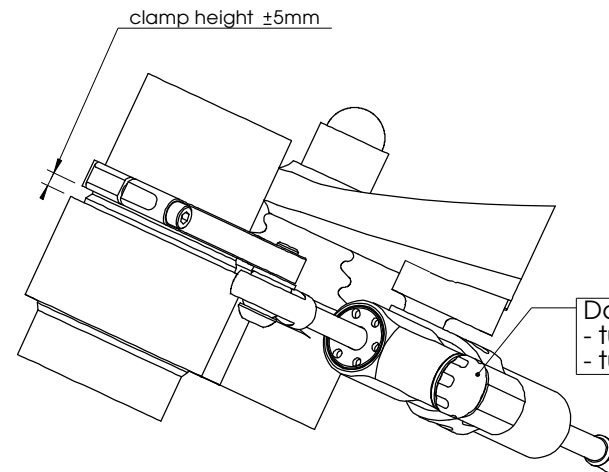
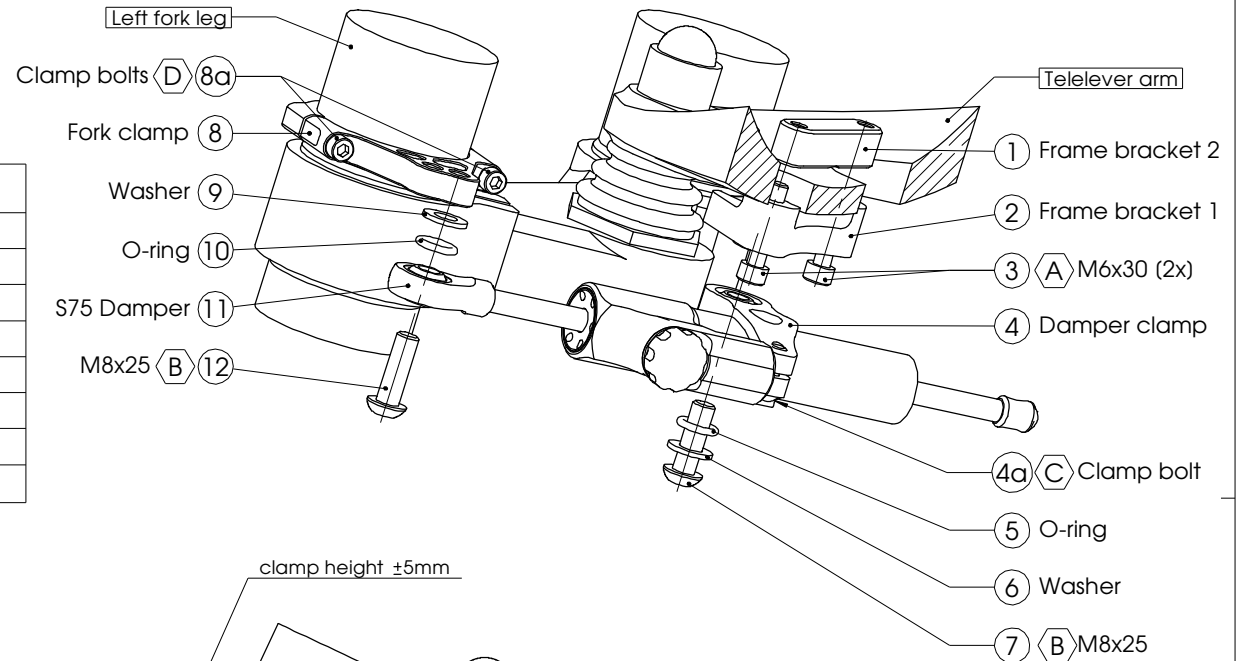
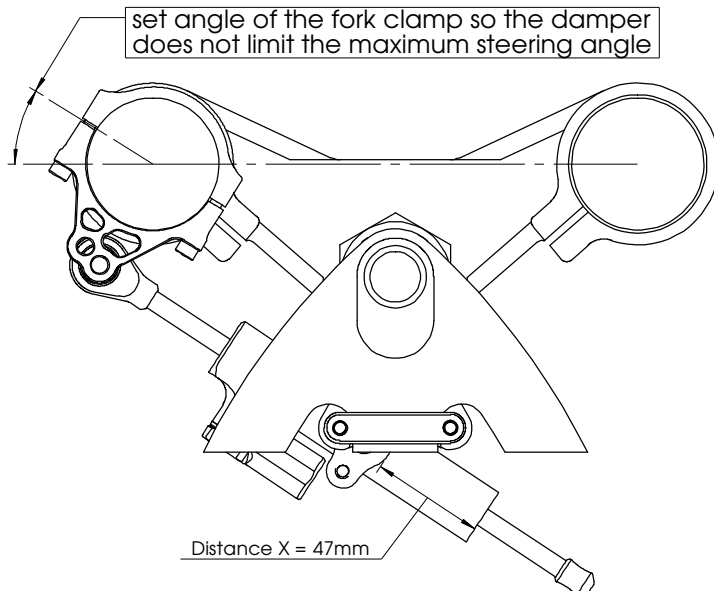

* TORQUES	
A: 5-9Nm / 44-80Lbs.In / 4.0-6.4Lbs.Ft	D: 8Nm / 70Lbs.In / 5.9Lbs.Ft
B: 14-17Nm / 124-150Lbs.In / 10.3-12.5Lbs.Ft	E: 55Nm / 486Lbs.In / 40Lbs.Ft
C: 6Nm / 53Lbs.In / 4.4Lbs.Ft	F: Factory torque (see owners manual)

HYPERPRO

STEERING DAMPER MOUNTING KIT

for

BMW R1200 GS (Adventure) Model 2004>

MK-BM12-B002 INSTALLATION INSTRUCTIONS

In general:

HYPERPRO can not be held responsible in any way for any form of physical, material, financial or other damage arising from use, assembly or overhaul of HYPERPRO products.
HYPERPRO reserves the right to make changes without prior notice.

This product is ONLY TO BE INSTALLED BY A PROFESSIONAL MECHANIC.

This product is only to be used for the motorcycle brand, model and year stated specifically on top of the pages of this manual.

DO NOT attempt to install this product on motorcycles from any different brand, model and/or year than stated on the pages of this manual.

DO NOT use this kit for cars, boats, jet-skies, snowmobiles, ATV's, aircraft, hovercrafts or any other vehicle and/or purpose.

HYPERPRO steering dampers are FOR RACE USE ONLY, NOT FOR HIGHWAY USE!

Before installation:

- Please read the entire manual carefully before starting the installation!
- Check if you have all the tools required. Good tools are a must.
- Protect your bike at the most important places in and around the work area (e.g. tank, fairing, frame, etc.), with a blanket, towel or similar.

During installation:

- Check all operations and parts carefully before, during and after performing each step.
- Clean all surfaces that are required for fitting parts together or for applying self adhesives or loctite, thoroughly with contact cleaner or another degreaser, unless otherwise stated.
- Be careful not to damage or scratch any part of your bike.
- ALWAYS work relaxed and concentrated!! It is very easy to damage something or make a mistake.

After installation:

- Check and make sure that there is no contact between any part of the steering damper kit and any part of the motorcycle. The kit should not hit anything. Steering movement should not be limited by the steering damper. If the steering movement is limited, adjust the position of the tube in the clamp until steering movement is normal again. Do not forget to tighten the clamp bolt again!
- ALWAYS check the steering movement and feeling before each ride!
- FIRST RIDES: Start with the damper turned fully open (turn adjuster knob fully counter clockwise). Start adjusting in between rides with steps of MAX. 2 CLICKS (0.25 TURN) EACH TIME, until the damper is working satisfactory for your riding style.
- NEVER USE MAXIMUM SETTING, ALWAYS OPEN AT LEAST 2 CLICKS (0.25 TURN).
- WARNING ! DAMPER HAS AN ACTIVE / SPEEDSENSITIVE DAMPING SYSTEM;
 - Steering with NORMAL MOVEMENT should be FREE !!
 - Steering with FAST MOVEMENT should be CONTROLLED BY DAMPER !!
- HYPERPRO uses a special seal to reduce friction. The seal uses an oil film to work properly. It is normal that some oil can appear on the pistonrod.
- Damper works with oil: DAMPING CAN BE HARDER AT LOWER TEMPERATURES!

Step 1: install the frame bracket assembly

- Frame bracket parts (1) & (2)
- 2x Bolt M6x30 (3)
- Damper Clamp (4)
- O-ring (5)
- Washer M8 ϕ 16 (6)
- M8x25 Button head (7)

The brackets (1) and (2) are to be clamped around the center part of the telelever arm. Place frame bracket (1) ON TOP, place the frame bracket (2) UNDERNEATH the telelever and use the bolts M6x30 (3) to clamp them. Make sure the parts are as far to the front as possible and tighten the bolts (3) with a torque of approx. 5-9Nm/44-80Lbs.In/4.0-6.4Lbs.Ft.

Install the damper clamp (4), O-ring (5), washer (6) and bolt M8x25 (10) to the bottom of frame-bracket (2). Tighten the bolt with a torque of approx. 14-17Nm/124-150Lbs.In/10.3-12.5Lbs.Ft.

Step 2: install the fork clamp

- Fork bracket ϕ 55 (8)

Disassemble the fork clamp (8). Re-assemble the parts around the left fork leg, about 5mm above the lower triple clamp as shown in the pictures. Make sure the clamp is orientated correctly, the most outer hole on the inside (see left picture). Set the angle as close as possible to the drawing and tighten the bolts (8a) evenly to a torque of approx. 8Nm/70Lbs.In/5.9Lbs.Ft each.

It may be necessary to adjust the angle of the fork clamp after step 3.

Step 3: installing the steering damper

- Steering damper (15)
- Washer M8 ϕ 16 (13)
- 1x O-ring (14)
- Bolt M8x25 button head (16)

Ensure that the clamp bolt (4a) of the damper clamp is pointing backward. Shove the damper (11), with the knob-end first, through the clamp until the distance "X" stated on page 1 is reached, then tighten the clamp bolt (4a) with a torque of approx. 6Nm/53Lbs.In/4.4Lbs.Ft.

Use the washer (9), O-ring (10) and M8x25 bolt (12) to mount the ball-joint to the bottom of the fork bracket and tighten with a torque of approx. 14-17Nm/124-150Lbs.In/10.3-12.5Lbs.Ft.

Check if the damper does not touch anything when steering from left to right.

Check if the bike can make it's full steering angle from left to right, adjust the angle of the fork clamp if necessary.